

MAC 550F

Flameless Air Heater

Owner's Manual

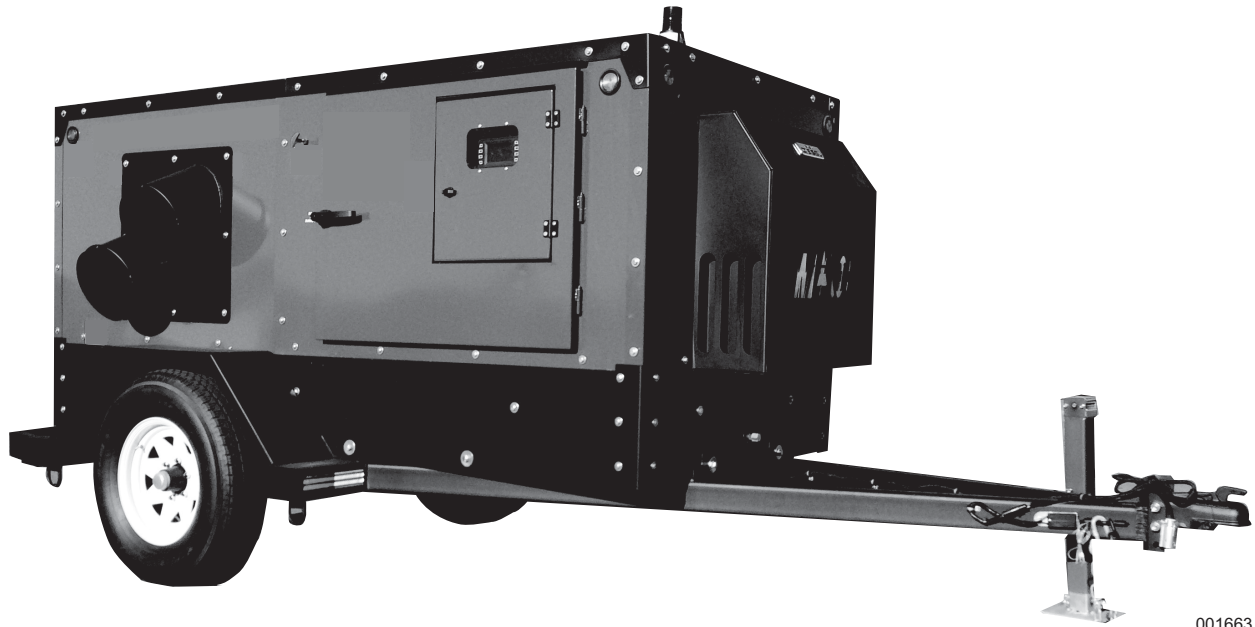

001663

MODEL NUMBER: _____

SERIAL NUMBER: _____

DATE PURCHASED: _____

Register your Generac Mobile product at:
WWW.GENERACMOBILE.COM
800-926-9768

SAVE THIS MANUAL FOR FUTURE REFERENCE

⚠ WARNING

California Proposition 65. Engine exhaust and some of its constituents are known to the state of California to cause cancer, birth defects, and other reproductive harm. (000004)

⚠ WARNING

California Proposition 65. This product contains or emits chemicals known to the state of California to cause cancer, birth defects, and other reproductive harm. (000005)

Table of Contents

Section 1 Introduction and Safety

Introduction	1
Safety Rules	1
General Hazards	2
Explosion and Fire Hazards	2
Trailer Hazards	2
Battery Hazards	3

Section 2 General Information

Component Locations	5
Emissions Information	6
Engine Oil Recommendations	6
Coolant Recommendation	6
Fuel System	6
Hydraulic Oil	7
Trailer Towing Guidelines	7
Wheel Chock Guidelines	7
Informational Decals	7
Controller	8
Monitoring, Diagnostic, and Protective Features	8

Section 3 Operation

Before Starting Engine	9
Pre-start Checklist	9
Engine Oil Check	9
Hydraulic Oil Check	9
Engine Coolant Check	9
Battery Check	9
Engine and Heater Startup	10
Adjusting Heater Output	11
AUTO Mode	11
MANUAL Mode	11
Heater and Engine Shutdown	11

Section 4 Maintenance

Maintenance Tasks	13
Daily Walk Around Inspection	13
Check Engine Oil Level	13
Drain the Oil	13
Adding Coolant	14
Maintenance Schedule	14
Engine Maintenance Schedule	15
Other Maintenance Checks	16
Battery Inspection	17
Battery Installation and Replacement	17

Section 5 Troubleshooting

General Troubleshooting Guide	19
Digital Controller Status Messages	21

Section 6 Installation Diagrams and Service Log

Engine Harness (1 of 3)	23
Engine Harness (2 of 3)	24
Engine Harness (3 of 3)	25
Trailer Wiring Harness	26
Service Log	27

This page intentionally left blank.

Section 1 Introduction and Safety

Introduction

Thank you for purchasing a Generac Mobile Products LLC product. This unit has been designed provide high-performance, efficient operation, and years of use when maintained properly.

The MAC 550F flameless air heater is designed and built for sustained, reliable heat production in industrial operating conditions and environments. The MAC 550F is built to withstand rough and frequent handling.

The unit is mounted on a trailer that has forklift access and chain attach points on both sides. The fully enclosed design protects the operating components, allowing all-weather storage and operations. .



Consult Manual. Read and understand manual completely before using product. Failure to completely understand manual and product could result in death or serious injury. (000100a)

If any section of the manual is not understood, contact your nearest Independent Authorized Service Dealer (IASD), or contact Generac Customer Service at

1-800-926-9768, or www.generacmobile.com with any questions or concerns.

The owner is responsible for proper maintenance and safe use of the equipment.

SAVE THESE INSTRUCTIONS for future reference. This manual contains important instructions for the heater that should be followed during installation, operation and maintenance of the heater and batteries. ALWAYS supply this manual to any individual that will use this machine.

THE INFORMATION CONTAINED HEREIN WAS BASED ON MACHINES IN PRODUCTION AT THE TIME OF PUBLICATION. GENERAC RESERVES THE RIGHT TO MODIFY THIS MANUAL AT ANY TIME.

Safety Rules

The manufacturer cannot anticipate every possible circumstance that might involve a hazard. The warnings in this manual, and on tags and decals affixed to the unit are, therefore, not all inclusive. If using a procedure, work method or operating technique that the manufacturer does not specifically recommend, verify that it is safe for others. Also make sure the procedure, work method or operating technique utilized does not render the equipment unsafe.

Throughout this publication, and on tags and decals affixed to the unit, DANGER, WARNING, CAUTION and NOTE blocks are used to alert personnel to special instructions about a particular operation that

may be hazardous if performed incorrectly or carelessly. Observe them carefully. Their definitions are as follows:



Indicates a hazardous situation which, if not avoided, will result in death or serious injury.

(000001)



Indicates a hazardous situation which, if not avoided, could result in death or serious injury.

(000002)



Indicates a hazardous situation which, if not avoided, could result in minor or moderate injury.

(000003)

NOTE: Notes contain additional information important to a procedure and will be found within the regular text of this manual.

These safety warnings cannot eliminate the hazards that they indicate. Common sense and strict compliance with the special instructions while performing the action or service are essential to preventing accidents.

General Hazards



⚠ DANGER

Asphyxiation. Running engines produce carbon monoxide, a colorless, odorless, poisonous gas. Carbon monoxide, if not avoided, will result in death or serious injury. (000103)



⚠ DANGER

Hydraulic Fluid Injection. High-pressure, high-temperature hydraulic fluid can pierce skin and cause severe burns. Do not check for leaks with hands. Seek immediate medical attention in case of accident. Failure to protect body accordingly will result in death or serious injury. (000239)

⚠ WARNING

Do not operate this unit while transporting. Doing so could result in death or serious injury. (000231)



⚠ WARNING

Hearing Loss. Hearing protection is recommended when using this machine. Failure to wear hearing protection could result in permanent hearing loss. (000107)



⚠ WARNING

Moving Parts. Keep clothing, hair, and appendages away from moving parts. Failure to do so could result in death or serious injury. (000111)



⚠ WARNING

Hot Surfaces. When operating machine, do not touch hot surfaces. Keep machine away from combustibles during use. Hot surfaces could result in severe burns or fire. (000108)

⚠ CAUTION

Equipment or property damage. Do not block air intake or restrict proper air flow. Doing so could result in unsafe operation or damage to unit. (000229)

⚠ CAUTION

Unit damage. Do not stop engine before heating unit is cooled. Doing so could result in unit damage. (000240a)

Explosion and Fire Hazards



⚠ DANGER

Explosion and Fire. Fuel and vapors are extremely flammable and explosive. Add fuel in a well ventilated area. Keep fire and spark away. Failure to do so will result in death or serious injury. (000105)



⚠ WARNING

Risk of Fire. Unit must be positioned in a manner that prevents combustible material accumulation underneath. Failure to do so could result in death or serious injury. (000147)

Trailer Hazards

⚠ WARNING

Trailer must be securely coupled to the hitch and chains correctly attached. Uncoupled or unchained towing could result in death or serious injury. (000233)

⚠ WARNING

Verify unit is properly secured with wheel chocks and on level ground. Failure to do so could result in death or serious injury. (000234)

⚠ WARNING

Property or Equipment Damage. Tighten wheel lug nuts after first 50 miles to factory specifications. Failure to do so could result in death, serious injury, property or equipment damage. (000235)

Battery Hazards

**⚠️ WARNING**

Explosion. Batteries emit explosive gases while charging. Keep fire and spark away. Wear protective gear when working with batteries. Failure to do so could result in death or serious injury. (000137a)

**⚠️ WARNING**

Explosion. Do not dispose of batteries in a fire. Batteries are explosive. Electrolyte solution can cause burns and blindness. If electrolyte contacts skin or eyes, flush with water and seek immediate medical attention. (000162)

**⚠️ WARNING**

Risk of burn. Do not open or mutilate batteries. Batteries contain electrolyte solution which can cause burns and blindness. If electrolyte contacts skin or eyes, flush with water and seek immediate medical attention. (000163a)

⚠️ WARNING

Environmental Hazard. Always recycle batteries at an official recycling center in accordance with all local laws and regulations. Failure to do so could result in environmental damage, death or serious injury. (000228)

This page intentionally left blank.

Section 2 General Information

Component Locations

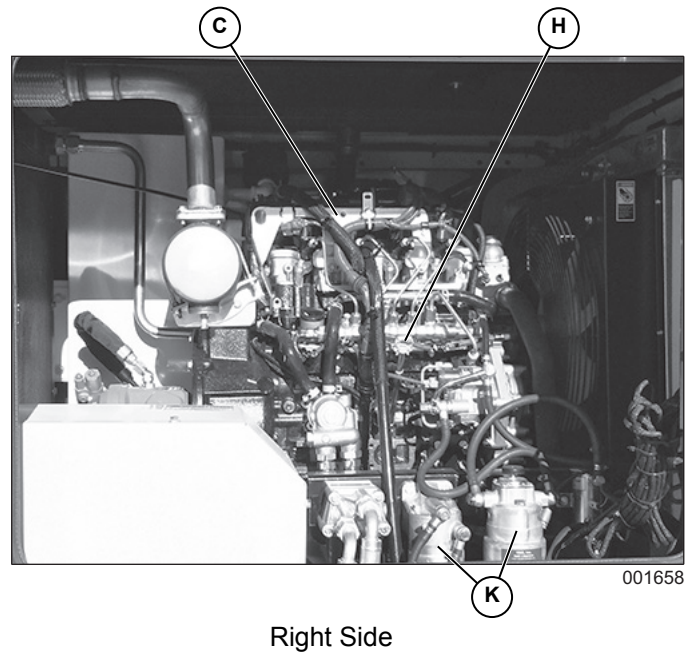
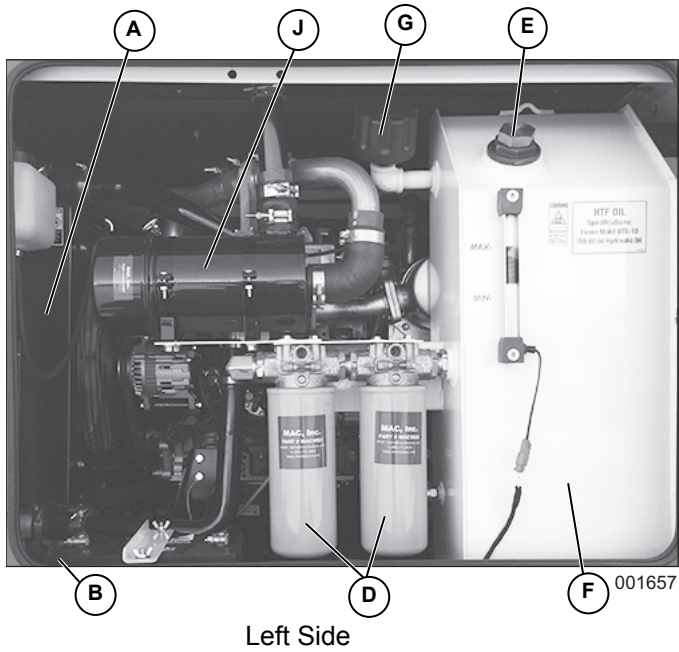

Table 1 - Heater Components

A	Engine radiator	F	Hydraulic fluid reservoir tank
B	Breakaway battery for trailer brakes	G	Hydraulic fluid breather/separator
C	Diesel engine	H	Engine oil dipstick
D	Hydraulic fluid filters	J	Air filter
E	Hydraulic fluid fill	K	Engine fuel filters

Emissions Information

For emissions information, see the OEM manual.

Engine Oil Recommendations

Grade	Type
API	CD, CE, CF, CF-4, CH-4, CI-4, CI-4 plus
ACEA	A3/B3, A3/B4, A5/B5, E2, E3, E4, E5, E7
JASO	DH-1

NOTE: Certain brands/types of oil can be used regardless of specified API or ACEA grade.

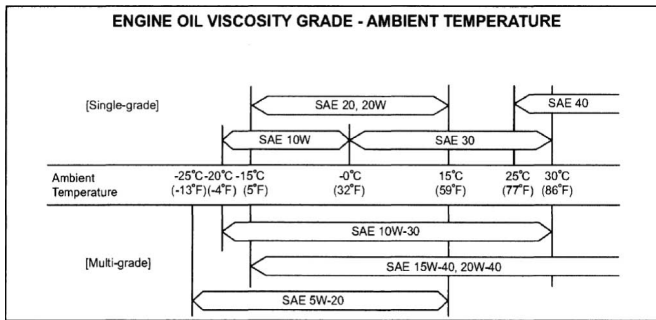

001577

Figure 2-1. Engine Oil Viscosity Chart for 550F

NOTE: For temperatures below -13° F (-25° C), use SAE 5W30.

Engine capacity: 9.8-12.9 qt (9.3-12.1 L).
For more information, see the engine manual.

Coolant Recommendation



⚠ DANGER

Risk of poisoning. Do not use mouth to siphon coolant. Doing so will result in death or serious injury.

(000149)

Use of improper coolants can damage the engine cooling system. Use demineralized water or distilled water for best results. Hard water causes scale deposits, which reduces cooling efficiency and raises internal temperatures, possibly leading to engine damage.

Where the atmospheric temperature falls below freezing point, the cooling system should be drained after engine operation, but to eliminate the need for repeated draining and refilling, the use of antifreeze solution is highly recommended. Follow these antifreeze/water guidelines:

- A 50/50 ethylene glycol base antifreeze/water mix, which provides protection to -34° F (-37° C), is recommended for use in this engine.

- Never exceed a 60/40 antifreeze/water mix, which provides protection to about -58° F (-50° C).
- Any coolant must be nitrite free and meet the performance standards of ASTM D6210.

System capacity (engine only): 4.5 qt (4.3 L).
For more information, see the engine manual.

Fuel System

⚠ DANGER



Explosion and Fire. Fuel and vapors are extremely flammable and explosive. Keep fire and spark away. Failure to do so will result in death or serious injury. (000168)

⚠ DANGER



Explosion and Fire. Do not overfill fuel tank. Overfilling may cause fuel to leak and ignite or explode, resulting in death or serious injury. (000204)

The engine is designed to use either Number 1-D or Number 2-D diesel fuel.

- For better fuel economy, use Number 2-D diesel fuel whenever possible.
- At temperatures below 20° F (-7° C), use Number 1-D or a winterized blend (check with the service station operator to ensure you get the properly blended fuel).

The following are required for the diesel fuel:

- Must be free from dust particles
- Must have adequate viscosity
- Must have high cetane value
- Must have high fluidity at low temperature
- Must have low or ultra-low sulfur content
EPA requirement; varies by geographic location
- Must have little residual carbon

Applicable Standard	Recommendation
JIS (Japanese Industrial Standard)	No. 2
DIN (Deutsche Industrie Normen)	DIN 51601
SAE (Society of Automotive Engineers) Based on SAE-J-313C	No. 2-D
BS (British Standard) Based on BS/2869-1970	Class A-1

If fuel other than what is specified is used, engine function will be lowered. For more information, see the engine manual.

Fuel tank capacity: 159 gal (602 L).

Hydraulic Oil



⚠ DANGER

Hydraulic Fluid Injection. High-pressure, high-temperature hydraulic fluid can pierce skin and cause severe burns. Do not check for leaks with hands. Seek immediate medical attention in case of accident. Failure to protect body accordingly will result in death or serious injury. (000239)

Type: Exxon Mobile DTE-10 ISO VG 68 hydraulic oil.
System capacity: 23 gal (87 L).

Trailer Towing Guidelines

⚠ WARNING

Trailer must be securely coupled to the hitch and chains correctly attached. Uncoupled or unchained towing could result in death or serious injury. (000233)

⚠ WARNING

Property or Equipment Damage. Tighten wheel lug nuts after first 50 miles to factory specifications. Failure to do so could result in death, serious injury, property or equipment damage. (000235)

Driving a vehicle with a trailer in tow is vastly different than driving the same vehicle without a trailer in tow. Consider the following:

- It takes longer to get up to speed
- More room is needed to turn and pass
- More distance is needed to stop
- The driver is responsible for keeping the vehicle and trailer in control

Before towing, verify the following:

- The coupling, safety chains, safety brake, tires, wheels, and lights are in working order
- The breakaway battery is fully charged
- Wheel lug nuts are tightened to 85-95 ft-lbs (115-129 Nm)
- Brake controller engages the trailer brakes before the tow vehicle brakes

While towing, make regular stops to verify the following:

- Coupler is secured to the hitch and locked
- Electrical connections are secure
- Appropriate slack in safety chains
- Appropriate slack in breakaway switch pull-pin cable
- Tires are inflated to proper air pressure and no damage or unusual wear to tread or sidewalls
- Trailer and doors are secured and latched

Wheel Chock Guidelines

⚠ WARNING

Verify unit is properly secured with wheel chocks and on level ground. Failure to do so could result in death or serious injury. (000234)

- Select wheel chock according to equipment type and size
- Always use in pairs and on firm surfaces
- Chock in direction of grade
- Chock both sides of wheel if direction of grade is unknown
- Use wheel chock only after parking brake is applied and tested
- Center chocks squarely against tread of each wheel
- Do not drive over wheel chocks

Informational Decals

Location	Decal Description
On back of right-side door	<ul style="list-style-type: none"> • Decal shows tire and loading information • Manufacturer's decal shows VIN #, model #, date of manufacture, GVWR, vehicle class, and tire and rim size • Emissions decal
Inside unit, right side, riveted to partition	<ul style="list-style-type: none"> • Blue and silver metal tag shows serial #, Model #, VIN, and MAC phone #
Front of trailer, near jack	<ul style="list-style-type: none"> • Tire and loading information • Decal shows VIN #, model #, date of manufacture, GVWR, and tire and rim size

Controller

For troubleshooting, see [Digital Controller Status Messages](#).



Figure 2-2. Controller

Button Position	Manual Mode	Auto Mode
A	Increase heat	Increase temperature setting
B	Increase fan	Decrease temperature setting
C	Overview/Analog gauge screen	
D	Main menu	
E	Heater on/off	
F	Next screen	
G	Popup "Softkeys"	

Monitoring, Diagnostic, and Protective Features

The unit's mechanical and electrical systems are connected to various sensors that monitor unit status. If conditions occur outside of predetermined manufacturing parameters, the controller will automatically stop the machine and display fault information. The controller can also display a variety of critical alerts, diagnostics, and recommendations. The controller provides a variety of real-time current operating condition data. For more information, see the engine harness wiring diagrams.

Section 3 Operation

Before Starting Engine

Pre-start Checklist



⚠️ WARNING

Hot Surfaces. When operating machine, do not touch hot surfaces. Keep machine away from combustibles during use. Hot surfaces could result in severe burns or fire. (000108)

- Remove all flammable materials and fire hazards within 5 ft (1.5 m) of heater
- Keep heater a minimum of 5 ft (1.5 m) from structures or barricades
- Verify unit is not leaking fluids: check inside and outside the unit for leaking fuel, engine oil, HTF/ hydraulic oil, and engine coolant
- Verify following are clear of debris and obstructions:
 - Engine air intake
 - Engine exhaust stack
 - Outlets and fan intakes
- Verify air duct hose is securely fastened to outlet duct assembly
- Check fuel, engine oil, and engine coolant levels
- Verify unit is properly secure (jack deployed, wheels chocked) and level
- Check alternator drive belt for tension and wear

Engine Oil Check

⚠️ CAUTION

Engine damage. Verify proper type and quantity of engine oil prior to starting engine. Failure to do so could result in engine damage. (000135)

1. Remove dipstick from crankcase and wipe it clean.
2. Insert dipstick fully and remove slowly.
3. Oil level must be between the *Full* and *Add* marks on the dipstick.

Hydraulic Oil Check

On the hydraulic fluid reservoir tank is a gauge showing hydraulic oil level. Verify the level is between MIN and MAX.

Engine Coolant Check



⚠️ WARNING

Risk of burns. Do not open coolant system until engine has completely cooled. Doing so could result in serious injury. (000154)

1. Remove radiator fill cap.
2. Check coolant level and degree of fouling. Level should be approximately 0.4 in (10 mm) below the radiator core top.
3. Install radiator cap securely.

Battery Check



⚠️ WARNING

Electrical shock. Disconnect battery ground terminal before working on battery or battery wires. Failure to do so could result in death or serious injury. (000164)



⚠️ WARNING

Risk of burn. Do not open or mutilate batteries. Batteries contain electrolyte solution which can cause burns and blindness. If electrolyte contacts skin or eyes, flush with water and seek immediate medical attention. (000163a)



⚠️ WARNING

Explosion. Batteries emit explosive gases while charging. Keep fire and spark away. Wear protective gear when working with batteries. Failure to do so could result in death or serious injury. (000137a)



⚠️ CAUTION

Do not make battery connections in reverse. Doing so will result in equipment damage. (000167)

1. Verify battery cable connections are not loose or corroded.
2. Verify battery electrolyte level is sufficient. If necessary, replenish with a commercially available electrolyte, such as distilled water.

Engine and Heater Startup

1. Close all doors that access the unit's interior.

IMPORTANT NOTE: All doors on the unit must be closed during operation.

2. Turn the ignition key to ON.
The screen displays "Engine Preheat" (*Figure 3-1*).

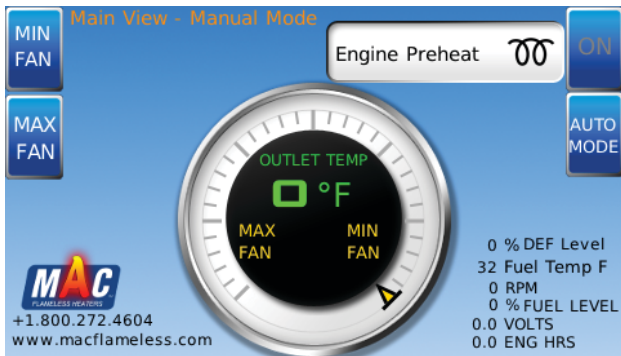

Figure 3-1. Engine Preheat

3. When the screen displays "Start Engine" (*Figure 3-2*), turn ignition key to START.

CAUTION

Equipment Damage. Do not continuously crank engine for more than ten seconds. Doing so will lead to overdischarge of batteries and starter seizure. (000230)

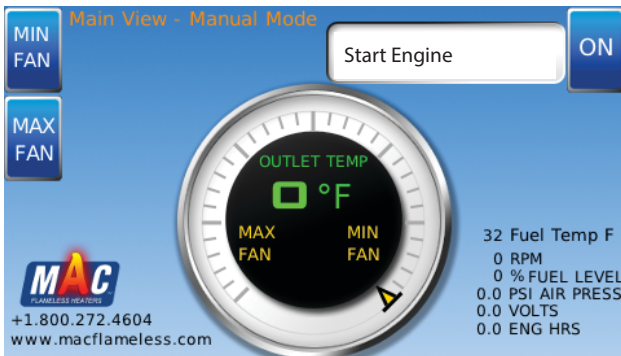

Figure 3-2. Start Engine

4. The screen displays "Engine Warming -- Please Wait." (*Figure 3-3*).

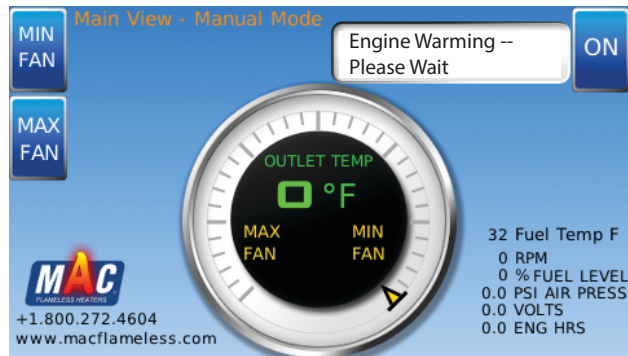

Figure 3-3. Engine Warming

5. When the coolant temperature reaches 140°F (60°C), engine warming is complete and the heater automatically begins warming. The screen displays "Heater is warming up--Please wait" (*Figure 3-4*).

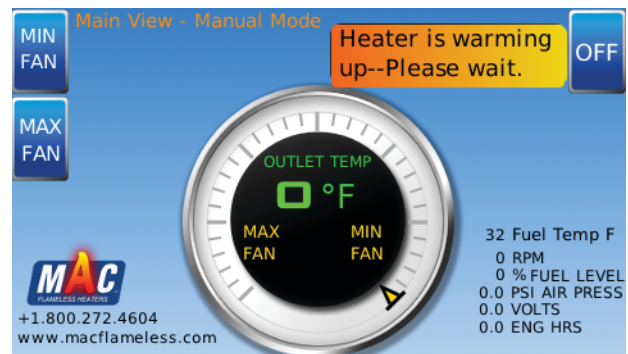

Figure 3-4. Heater Warming

When the heater is warm, heat begins blowing from ducts and the screen displays "Heater On--Press Off to stop the heater" (*Figure 3-5*).

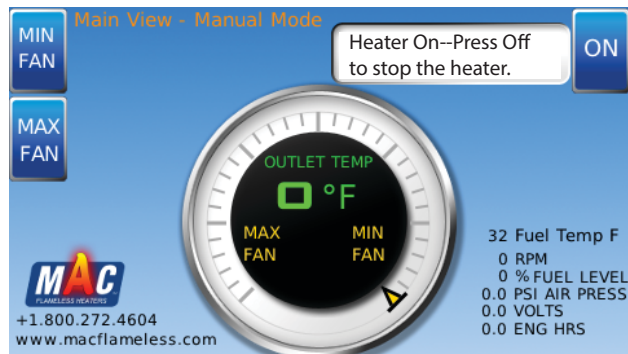

Figure 3-5. Heater On

Adjusting Heater Output

The heater has two modes, AUTO and MANUAL. The current mode displays at the top of the controller screen.

AUTO Mode

In AUTO mode, output temperature is manually set, as follows:

- To increase output temperature, press (+) (*Figure 3-6*, item A)
- To decrease output temperature, press (-) (*Figure 3-6*, item B)

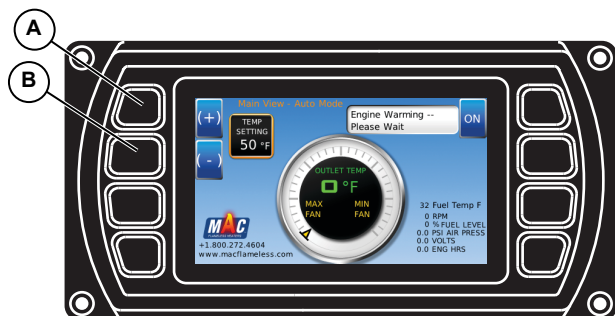

Figure 3-6. AUTO Mode

001578

MANUAL Mode

In MANUAL mode, heater output can be set to minimum fan or maximum fan, as follows:

- For minimum fan, press MIN FAN (*Figure 3-7*, item A)
- For maximum fan, press MAX FAN (*Figure 3-7*, item B)

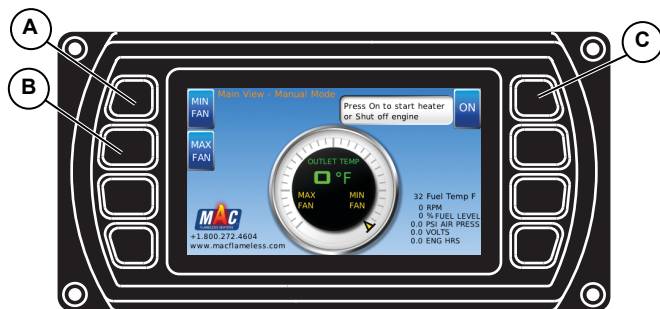
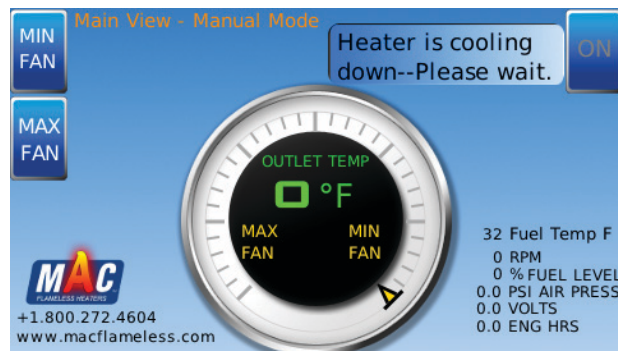

Figure 3-7. MANUAL Mode

001579

Heater and Engine Shutdown

1. Press OFF to stop the heater (*Figure 3-7*, item C). The screen displays “Heater is cooling down--Please wait” (*Figure 3-8*).



001582

Figure 3-8. Heater Cooling

NOTE: While cooling, the ON button is disabled.

When cooling is complete, the screen displays as shown in *Figure 3-9*.

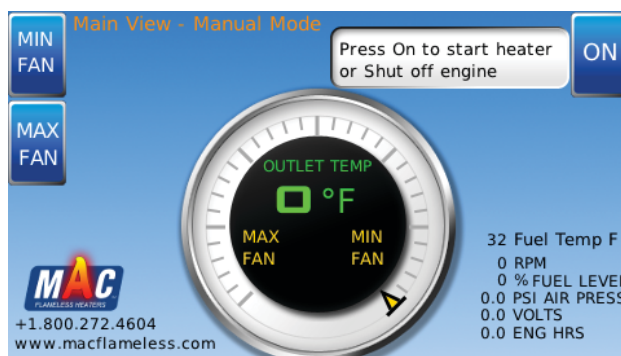

001583

Figure 3-9. Cooling Complete



Unit damage. Do not stop engine before heating unit is cooled. Doing so could result in unit damage.

(000240a)

2. When the control screen indicates it is safe to turn off the engine, turn the ignition key to OFF.

This page intentionally left blank.

Section 4 Maintenance

Regular maintenance will improve performance and extend engine/equipment life. Generac Power Systems, Inc. recommends that all maintenance work be performed by an Independent Authorized Service Dealer (IASD). Regular maintenance, replacement or repair of the emissions control devices and systems may be performed by any repair shop or person of the owner's choosing. However, to obtain emissions control warranty service free of charge, the work must be performed by an IASD. See the emissions warranty.

NOTE: Normal maintenance service and replacement of parts is the responsibility of the owner and, as such, are not considered defects in materials or workmanship within the terms of the warranty. It is strongly recommended that equipment be periodically checked by an IASD.

Maintenance Tasks

Daily checks must be performed when unit is operated continuously for extended periods of time. Daily checks and routine monthly checks can be performed by an authorized operator.

Daily Walk Around Inspection

Look for conditions that could hinder performance or safety, such as (but not limited to) oil, coolant, fuel leakage, blocked vents, loose or missing hardware and electrical connections. Check for foreign matter blocking the vents and on top of unit.

- Visually inspect outer cover for significant damage beyond scuffs and small nicks.
- Visually inspect for wire abrasion.
- Visually inspect the fan belt for cracks, fraying and stretching. Verify the belt is properly seated in the pulley grooves. Every 750 hours, it is recommended that the belt be removed and checked for wear. While the belt is removed, inspect pulleys and bearing. Rotate and feel for hard turning or unusual sounds.
- Coolant should be checked daily.
- Check electrical connectors, battery and ground points. Look for loose or missing hardware.
- Check all flexible rubber hoses for deterioration.
- Check hydraulic hoses for signs of wear.
- Verify hoses are not crushed, kinked or twisted.
- Verify there are no cracks or corrosion.

Check Engine Oil Level



Engine damage. Verify proper type and quantity of engine oil prior to starting engine. Failure to do so could result in engine damage.

(000135)

NOTE: If engine was running, wait at least ten minutes before proceeding.

1. Remove dipstick and wipe it dry with a clean, lint free cloth.
2. Slowly insert the clean dipstick into the tube. Verify the dipstick is fully seated in the dipstick tube.
3. After ten seconds, remove the dipstick and look at the oil level on both sides. The lower of the two readings is the correct oil level measurement.
4. Add oil (if necessary) to adjust the level. After adding or changing the oil, run the engine for one minute before checking the oil level. Wait ten minutes to allow the engine to cool and oil to fully drain into the oil pan.

Typical causes of inaccurate oil level readings:

- Reading the high level of the dipstick
- Reading the dipstick before the oil fully drains into the oil pan
- Inserting and removing the dipstick too quickly
- The dipstick is not fully seated in the dipstick tube

Drain the Oil



Risk of burns. Allow engine to cool before draining oil or coolant. Failure to do so could result in death or serious injury.

(000139)



Potential of cancer. Prolonged or repeated contact with used motor oil has been shown to cause cancer in laboratory animals. Thoroughly wash exposed areas with soap and water.

(000127a)

1. Place container under drain port, or connect hose or piping to drain port leading to container.
2. Remove plug from oil drain/manifold.
3. Open drain valve.
4. See engine manual for oil filter information.
5. Close drain valve.
6. Remove hose or piping if applicable.

- Replace plug in drain port on sub base.

Adding Coolant



⚠ DANGER

Risk of poisoning. Do not use mouth to siphon coolant. Doing so will result in death or serious injury.

(000149)



⚠ WARNING

Risk of burns. Do not open coolant system until engine has completely cooled. Doing so could result in serious injury.

(000154)

⚠ CAUTION

Do not use any chromate base rust inhibitor with propylene glycol base antifreeze, boosters or additives. Doing so will cause overheating.

(000165)

If coolant level is below the filler neck, coolant must be added. (See [Coolant Recommendation](#).)

- Verify engine is stopped and cooled.
- Remove radiator cap.
- Fill radiator slowly with coolant until it comes up to the filler neck.
- Operate engine approximately five minutes at a low idle speed to bleed the air in the coolant circuit.

NOTE: Coolant level will drop.

- Stop the engine and, once cooled, replenish with coolant.

Maintenance Schedule

Periodic inspection, service, and maintenance of this unit is critical to ensure reliable operation. The following is the manufacturer's recommended maintenance schedule. The maintenance items will need to be performed more frequently if the heater is used in severe applications (such as very high or very low ambient conditions or extremely dirty/dusty environments). Use the heater hour meter or calendar time, whichever occurs first, from the previous maintenance interval to determine the next required maintenance interval. Note that some checks are based on hours of operation.

Follow all applicable safety alerts found in this manual or engine service manual before performing any maintenance checks or service.

This maintenance schedule reflects the minimum tasks that need to be accomplished to verify the heater remains operational. Some of the tasks can be performed by an authorized operator and others must be performed by an IASD.

NOTE: An authorized operator is one who has been trained by a IASD in proper operation and inspection of this unit.

Engine Maintenance Schedule

To protect the warranty status of the engine, engine maintenance and repairs should be performed by an IASD. For more information on the checks and maintenance described below, see the engine manual.

Daily	<ul style="list-style-type: none"> • Check engine oil: <i>Level, leakage, and fouling</i> • Check coolant: <i>Level, leakage, and fouling</i> • Check hydraulic oil: <i>Level and filter restriction</i> • Check radiator filler cap fitting condition • Check alternator drive belt tension and replace if necessary • Check fan belt tension • Check trailer breakaway battery charge condition • Check preheating condition • Check engine starting condition • Check exhaust smoke condition • Check hoses and connections • Inspect exhaust system for wear and cracking
Every 6 Months	<ul style="list-style-type: none"> • Replace coolant
At 50 Operation Hours (Break-In)	<ul style="list-style-type: none"> • Change engine oil and oil filter • Change engine fuel filters
At 250 Operation Hours	<ul style="list-style-type: none"> • Replace fuel filter element • Clean water sedimenter element • Clean electromagnetic pump filter
At 500 Operation Hours	<ul style="list-style-type: none"> • Replace engine oil and oil filter element • Inspect engine accessory drive belts • Inspect fuel supply system • Replace engine fuel filters • Check alternator drive belt tension and replace if necessary • Check injection nozzle (*) • Replace fuel filter element • Clean water sedimenter element • Clean electromagnetic pump filter
At 750 Operation Hours	<ul style="list-style-type: none"> • Replace fuel filter element • Clean water sedimenter element • Clean electromagnetic pump filter
At 1000 Operation Hours	<ul style="list-style-type: none"> • Replace engine oil and oil filter element • Inspect engine accessory drive belts • Inspect fuel supply system • Clean cooling system circuit • Check and clean the starter and alternator(*) • Check cylinder compression pressure(*) • Check valve clearance(*) • Check injection nozzle (*) • Replace fuel filter element • Clean water sedimenter element • Clean electromagnetic pump filter
At 1250 Operation Hours	<ul style="list-style-type: none"> • Replace fuel filter element • Clean water sedimenter element • Clean electromagnetic pump filter

At 1500 Operation Hours	<ul style="list-style-type: none"> • Replace engine oil and oil filter element • Inspect engine accessory drive belts • Inspect fuel supply system • Clean positive crankcase ventilation valve • Check injection nozzle (*) • Replace fuel filter element • Clean water sedimenter element • Clean electromagnetic pump filter
After 1500 Operation Hours	All hours-based checks and maintenance should now be performed every 250 hours

(*) = When servicing these items, consult the equipment supplier.

NOTE: All service and maintenance or repairs are recommended to be completed by an IASD to maintain the warranty status of a unit. You cannot be denied emissions warranty coverage solely based on failure to complete recommended service maintenance.

Other Maintenance Checks

Every 500 Hours	<ul style="list-style-type: none"> • Change air filter
Every 1000 Hours	<ul style="list-style-type: none"> • Change hydraulic oil • Change hydraulic pump filters
Annually	<ul style="list-style-type: none"> • Replace hydraulic breather/separator • Carbon Monoxide (CO) test at outlet air duct by trained service technician • Check blower/fan hardware for condition and tightness

Battery Inspection



⚠ WARNING

Explosion. Batteries emit explosive gases while charging. Keep fire and spark away. Wear protective gear when working with batteries. Failure to do so could result in death or serious injury. (000137a)



⚠ WARNING

Explosion. Do not dispose of batteries in a fire. Batteries are explosive. Electrolyte solution can cause burns and blindness. If electrolyte contacts skin or eyes, flush with water and seek immediate medical attention. (000162)



⚠ WARNING

Risk of burn. Do not open or mutilate batteries. Batteries contain electrolyte solution which can cause burns and blindness. If electrolyte contacts skin or eyes, flush with water and seek immediate medical attention. (000163a)

⚠ WARNING

Accidental Start-up. Disconnect the negative battery cable, then the positive battery cable when working on unit. Failure to do so could result in death or serious injury. (000130)



⚠ WARNING

Vision Loss. Eye protection is required to avoid spray from spark plug hole when cranking engine. Failure to do so could result in vision loss. (000181)

⚠ WARNING

Environmental Hazard. Always recycle batteries at an official recycling center in accordance with all local laws and regulations. Failure to do so could result in environmental damage, death or serious injury. (000228)

NOTE: Remove five amp controller fuse from control panel.

An authorized operator should inspect the engine battery monthly. At this time, the battery fluid level should be checked using a load tester and distilled water added if needed. Battery cables and connections should also be inspected for cleanliness and corrosion.

Once every six months, an IASD should inspect the battery system. At this time, the battery condition and state of charge should be checked using a load test battery. The battery should be recharged or replaced as required.

Battery service is to be performed or supervised by personnel knowledgeable of batteries and the required

precautions. Keep unauthorized personnel away. Observe the following precautions when working on batteries:

- Remove watches, rings, or other metal objects.
- Use tools with insulated handles.
- Wear rubber gloves and boots.
- Do not lay tools or metal parts on top of battery.
- Disconnect charging source prior to connecting or disconnecting battery terminals.

NOTE: Spilled electrolyte is to be washed down with an acid neutralizing agent. A common practice is to use a solution of one pound (454 grams) bicarbonate of soda (baking soda) to one gallon (3.8 liters) of water. The bicarbonate of soda solution is to be added until the evidence of reaction (foaming) has ceased. The resulting liquid is to be flushed with water.

NOTE: Discharge static electricity before touching battery by first touching a grounded metal surface.

Battery Installation and Replacement

When required, the battery must be replaced with one of equivalent size, voltage, and CCA (cold crank amp capacity). Minimum CCA for this unit is 950. Contact the local IASD for correct battery size. A new battery must be filled with the proper electrolyte and be fully charged before install.

Battery cables are connected to the unit at the factory. Connect cables to battery posts as follows:



⚠ CAUTION

Do not make battery connections in reverse. Doing so will result in equipment damage.

(000167)

1. Connect battery cable from starter contactor to positive (POS or +) battery post.
2. Connect black battery cable to negative (NEG or -) battery post.
3. See *Engine and Heater Startup*.

This page intentionally left blank.

Section 5 Troubleshooting

General Troubleshooting Guide

Problem	Cause	Solution
Engine Cranks But Will Not Start	No fuel	Verify there is no fuel leakage and replenish
	Low oil level	Replenish oil to full
	Emergency shutdown switch is ON	Turn emergency shutdown switch OFF
	Air in fuel system	Bleed air
	Fuel filter is clogged	Remove water and change element
	Fuel is frozen	Warm fuel pipes with hot water or wait until ambient temperature rises
	Injection pump fails	Contact Generac Technical Service
	Electromagnetic type fuel pump failure	
	Engine control system failure	
	Restricted air flow	Check/replace air filter
	LCD Display panel shows engine failure	Contact Generac Technical Service
	Strainer is clogged	
Pre-heating device failure		
Engine Will Not Crank (Electric Start)	Dead battery	Replace battery
	Battery terminal is disconnected, loose, or corroded	Replace corroded part and tighten securely
	Starter ground terminal is disconnected, loose, or corroded	
	Engine oil viscosity is too high	Change with oil of correct viscosity
	Starter or electrical system failure	Contact Generac Technical Service
Engine Starts But Stops Shortly Thereafter	Idling is too low	<ul style="list-style-type: none"> Adjust by idling control equipment on the machine If adjustment is not possible, contact Generac Technical Service
	Fuel filter is clogged	Remove water and change element
	Pre-fuel filter is clogged	Clean or change element
	Air cleaner is clogged	
	Engine control system failure	Contact Generac Technical Service
	Injection pump failure	
	Strainer is clogged	
Electromagnetic type fuel pump failure		
Engine Running is Unstable	Fuel system failure	Bleed air or remove water
	Water or air is in fuel system	
	Engine control system failure	Contact Generac Technical Service

Problem	Cause	Solution
Exhaust Smoke is White	Needs more warm-up time	Conduct warm-up operation
	Too much engine oil	Correct oil level
	Engine control system fails	Contact Generac Technical Service
	Injection pump failure	
	Fuel system failure	Contact Generac Technical Service
Long time idling (more than two hours)		
Exhaust smoke is Black	Excessive speed	<ul style="list-style-type: none"> • Verify engine RPM • Check AVR adjustment
	Injection pump failure	Contact Generac Technical Service
	Air cleaner is clogged	Clean or change element
	Intercooler is clogged	Contact Generac Technical Service
	Fuel system failure	
	Exhaust system is clogged	
Engine Overheats	No coolant	Add coolant
	Front of radiator is clogged with dust	Clean with soft brush
	Sub tank cap is not tightened	Tighten or replace sub tank cap
	Coolant is fouled	Clean inside of radiator and change coolant
	Oil is in coolant	Contact Generac Technical Service
	Thermostat failure	Change thermostat
Oil Pressure Does Not Rise	Engine oil viscosity is incorrect	Change with oil of correct viscosity
	Engine oil level is not sufficient	Replenish
	Engine failure	Contact Generac Technical Service
	Meter, lamp, or switch failure	
Engine Has No Power	Air cleaner is clogged	Clean element
	Pre-fuel filter is clogged	
	Fuel filter is clogged	Remove water and change element
	Strainer is clogged	Contact Generac Technical Service
	Engine control system failure	
	Engine failure	
	Exhaust system is clogged	
	Fuel system failure	
	Type of fuel is incorrect	
Electromagnetic type fuel pump failure		
Overheat/shutdown condition	Access doors are open	Close all access doors
	Air outlets are not open	Open the air outlets and verify there are no obstructions or kinks in the ducting
	Front radiator or rear oil cooler are full of debris	Clean the machine
	Engine RPM is set too high based on ambient temperature	Lower the engine RPM
	Faulty temperature sensor	Check air outlet sensor operation
	Blower fan not operating correctly	Remove ducting; check blower fan operation

Problem	Cause	Solution
No/low heat condition	Incorrect heater setting (target temperature too low)	Adjust heater output
	Access doors are open	Close all access doors
	Low HTF/hydraulic oil level	<ul style="list-style-type: none"> • Check level on tank sight glass, adjust as needed • Inspect HTF hoses for leaks or loose fittings • Check fluid for foaming
	HTF/hydraulic oil filters clogged	Check restriction gauges/replace HTF filters
	Ducting too long for ambient conditions	Move unit closer to heat recipient if possible
	HTF pump drive sheared	Contact Generac technical service

Digital Controller Status Messages

Message	Cause
Engine Warming – Please Wait	Engine coolant temperature < 140° F (38° C)
Engine Preheat	Wait approximately ten seconds after heater power up
Engine is not ready – Check RPMs, Fuel Level or Wait to Start	Engine RPM < 500
	Fuel level < 10%
	Wait to Start signal
Low Fuel Warning	Fuel level < 20% <ul style="list-style-type: none"> • Fuel level notification appears on screen
	Fuel level ≤ 16% <ul style="list-style-type: none"> • Fuel level notification appears on screen • Heat/fan load reduced to 50%
	Fuel level ≤ 12% <ul style="list-style-type: none"> • Fuel level notification appears on screen • Open heat circuit and close scroll fan circuit • Drop engine to idle
	Fuel level ≤ 8% <ul style="list-style-type: none"> • Fuel level notification appears on screen • Engine shuts down
Check heater settings or connections, then Reset on the Machine Overview	IFM controller detected a short or break in a sender
Heater is cooling down – Please wait	IFM controller detects heater is in cool down. ON button disabled.
Engine is going to shutdown	Fuel level ≤ 8%
Engine Fault Shutdown	Low engine oil pressure
	High engine coolant temperature
	Engine overspeed
Heater Shutdown due to temperature, pressure or level out of range	High hydraulic temperature
	Low hydraulic pressure
	Low hydraulic level

This page intentionally left blank.

Section 6 Installation Diagrams and Service Log

Engine Harness (1 of 3)

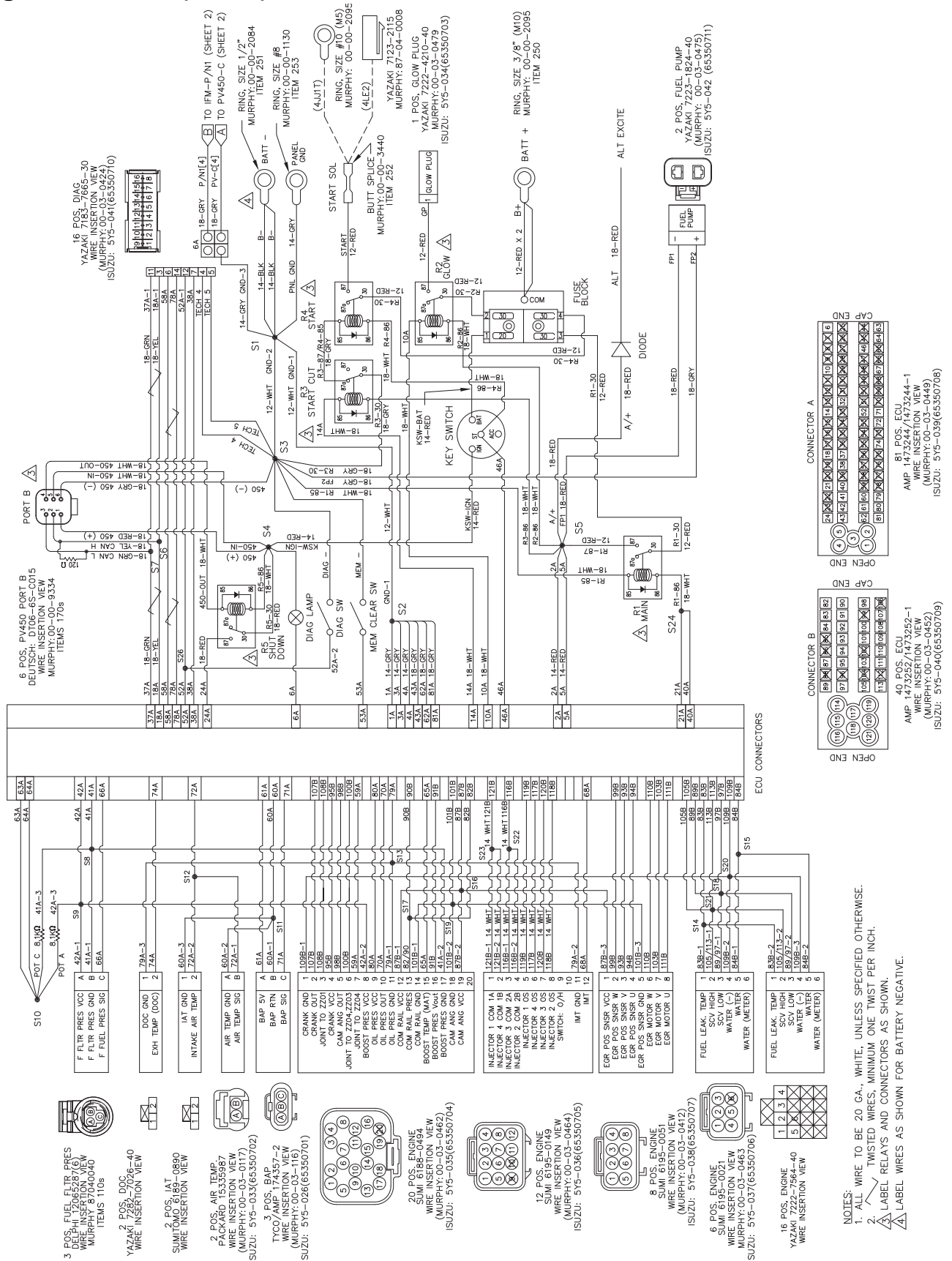

- NOTES:**
1. ALL WIRE TO BE 20 GA., WHITE, UNLESS SPECIFIED OTHERWISE.
 2. TWISTED WIRES, MINIMUM ONE TWIST PER INCH.
 3. LABEL RELAYS AND CONNECTORS AS SHOWN.
 4. LABEL WIRES AS SHOWN FOR BATTERY NEGATIVE.

Engine Harness (3 of 3)

NOTES:

1.  = 1/4" LOOM (00002874).
2. DRAWING IS NOT TO SCALE.
3. ALL DIMENSIONS ARE IN INCHES.
4. TAG WIRE ENDS OR CONNECTOR WITH LABELS SHOWN.
5. LOOM SHOULD START AT LEAST 3" FROM INSIDE OF THE PANEL.
6. LABEL CONNECTORS AS SHOWN.
7. USED ONLY FOR 4LE2 ENGINE.
8. USED ONLY FOR FT4 4JJIT ENGINE.
9. UNUSED CONNECTORS SHOULD BE COVERED WITH SHRINK TUBE AND TIDE BACK TO LOOM SECURELY.

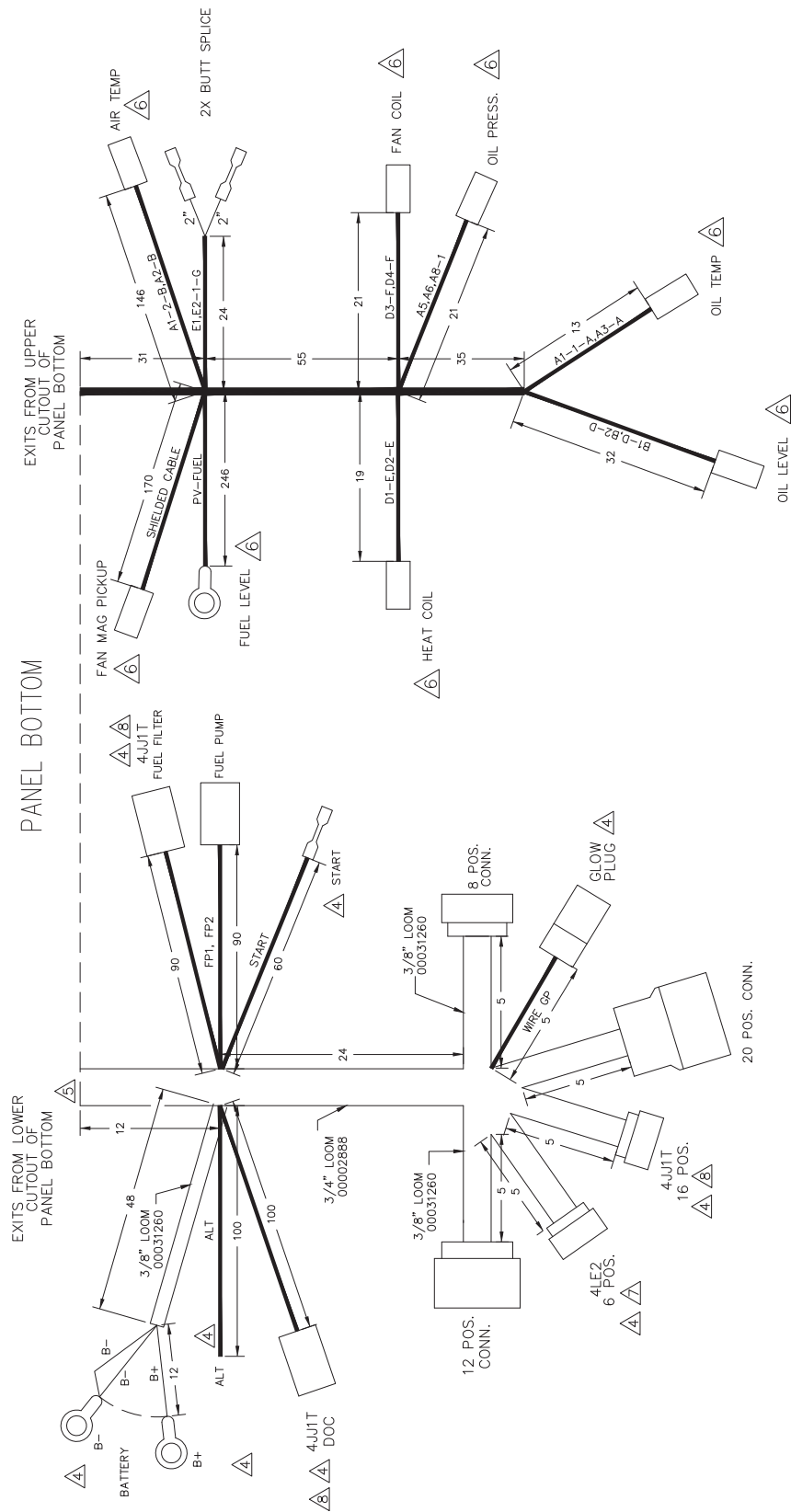

Trailer Wiring Harness

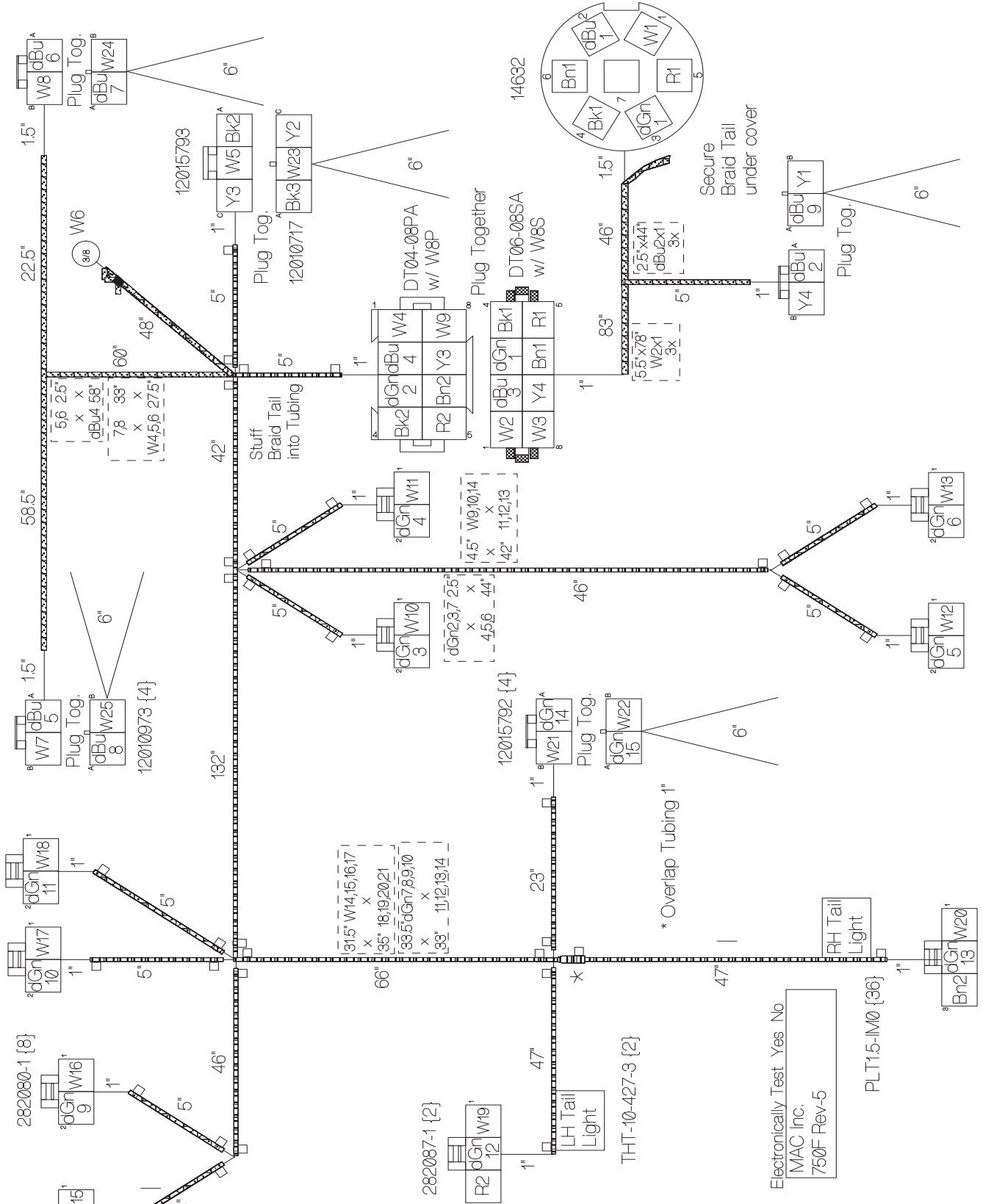

Service Log

OIL GRADE: _____ BRAND: _____

COOLANT MIXTURE: _____ BRAND: _____

Date	Hours to Service	Oil Level	Coolant Level

Date	Hours to Service	Oil Level	Coolant Level

This page intentionally left blank.

Part No. 3022146 Rev. A 11/10/15 Printed in USA
© Generac Power Systems, Inc. All rights reserved
Specifications are subject to change without notice.
No reproduction allowed in any form without prior written
consent from Generac Power Systems, Inc.

GENERAC® | **MAC**

Generac Power Systems, Inc.
S45 W29290 Hwy. 59
Waukesha, WI 53189
1-888-GENERAC (1-888-436-3722)
generacmobile.com